

THE NEWSLETTER OF THE NOTTINGHAM BRANCH NORTON OWNERS CLUB

FIND US AT :- THE FOX AT KELHAM, Nr NEWARK.
FIRST WEDNESDAY EVERY MONTH
ALSO AT :- THE ROSE & CROWN , CRESSWELL
SECOND TUESDAY EVERY MONTH
WEBSITE WWW.NOTTNOC.ORG

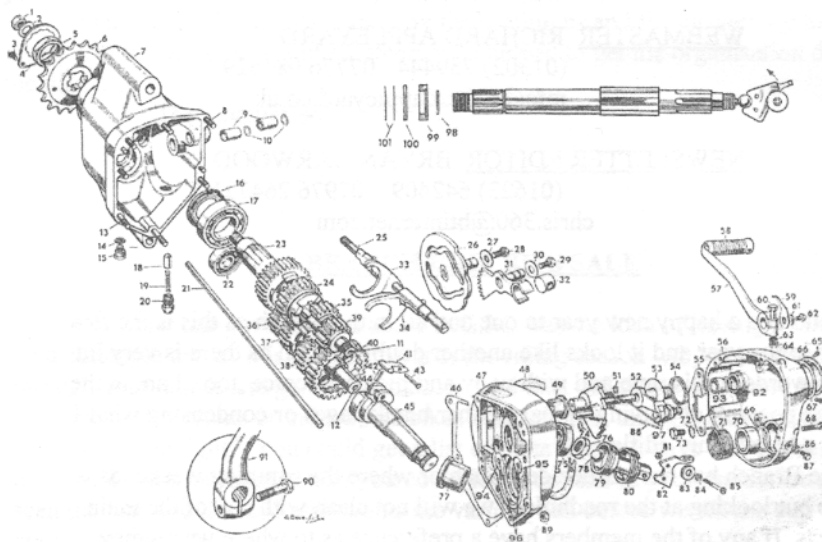

FIG. 25 The Gearbox

THE AMC GEARBOX AS FITTED TO MANY NORTONS ,POSTWAR.

FEBRUARY/MARCH 2011

COMMITTEE INFORMATION 2010-2011

CHAIRMAN RICHARD APPLEYARD
(01302)759444 , 07776 081529
info@richardappleyard.co.uk

SECRETARY GARY RACE
(01623) 470153
gary.race@ntlworld.com

TREASURER DON & MAVIS MEEK
(0115)9664646

EVENTS RICK SIMS
(01629) 580425 07791110769
ricksims@sky.com

REGALIA CHRISTINE HARWOOD
(01623) 642409 07875392676
chris.360@btinternet.com

WEBMASTER RICHARD APPLEYARD
(01302) 759444 07776 081529
info@richardappleyard.co.uk

NEWSLETTER EDITOR BRYAN HARWOOD
(01623) 642409 07976 264721
chris.360@btinternet.com

Hello and a happy new year to one and all in the branch as this is the first newsletter in the year and it looks like another double month as there is very little to put into words at this time and with copy and pictures scarce ,too , I am in the unfortunate position of having to leave either blank pages or condensing what I have into a bi-monthly edition .

The Branch has not yet decided when or where the camping weekends will take place but looking at the roadholder we will not clash with any of the main clubs events. If any of the members have a preference as to where we go they should let it be known to Rick ,our events planner and we will try to get it for you.

I do hope the rather inclement weather we had at the start of the year did not detract from your Norton tasks ? At least I managed to get a path cut to the garage ,through the snow to get my bike moved around so as to allow me work on the commando. Then the cold took hold of my toes and forced me back indoors to the warm and a beer or two to see in the new year!

See you all out and about soon? Bryan the editor.

NOTTS BRANCH CHRISTMAS DINNER 18TH DECEMBER 2010.

Many thanks to all those members and guests who came along to our branch xmas dinner at the Fox last December. There were 29 hardy souls who made it through the freezing conditions to attend and from comments made to me the meal was a success although we do not know how we ended up in the games room as it did not have the feel of Christmas as the main dining room had!!

Some thanked us for being in there as it was too hot last year and others did not like it as they could not get warm due to the draughts coming from the vents ?

With only a small hiccup due to a missing starter , we had our meals in pretty sharp time and we were all fed at around the same time so no one had to catch up at the end of a course.

This year we did not have a raffle as we thought it would disturb other diners but as we were alone in the room we could have had one anyway. So we will be having a raffle as discussed at the A,G,M, later in the year.

I have no photos of the occasion so I cannot include them here in the newsletter so if any of you have a picture could you let me borrow a copy and I will return it to you when I have scanned it into my computer, thanks.

Our thanks to the staff at the Fox for hosting us and for the serving to us on the night, also thanks to Rick and all others who helped to get the organisation done for the dinner .

The Committee.

BRANCH BIKE BITS SALE

Another thing we mooted at the A.G.M. was the idea of having a bike bits sale on a clubnight and as it is getting towards the riding season why not start to rummage through your sheds and garages and attics and dust off all the unwanted bits that you have for your Nortons or indeed and bikes and get them brought along to the Fox on the March clubnight? You could get a list of parts that you have and an idea of how much you want for them and so you could leave the bits in your car until we have all seen the lists and decided who wants the various bits before we fill the pub with large chunks of metal!!

Another thing is to please try to clean the bits up before bringing them along as the pub may not look favourably on us bringing in a lot of greasy oily bike parts into the bar.

Looking forward to seeing what you have to show there must be a lot of ~~stuff~~ tucked away in the members homes knowing what I have seen in the past .

EVENTS LIST

February 11

2nd Monthly meet at the Fox Kelham.

8th Social get together at the Rose and Crown.

12th 13th Classic off Road & race show at the international centre Telford.

March 11

2nd Monthly meet at the Fox Kelham.(BRING YOUR BIKE BITS)

8th Social get together at the Rose and Crown.

19th-20th Bristol classic motorcycle show, Shepton mallet

April 11

3rd AGM to be held at National Railway Museum York.

6th Monthly meet at the Fox Kelham.

12th Social get together at the Rose and Crown.

23rd-24th international classic bike show ,Stafford

29th-01stmay Shropshire branch camping weekend

As it is the winter there is not much to put into the events list.

Please remember to tell me if you know of any runs or meetings that you here about that other members of our branch might like to go on. To contact me look on the inside page.

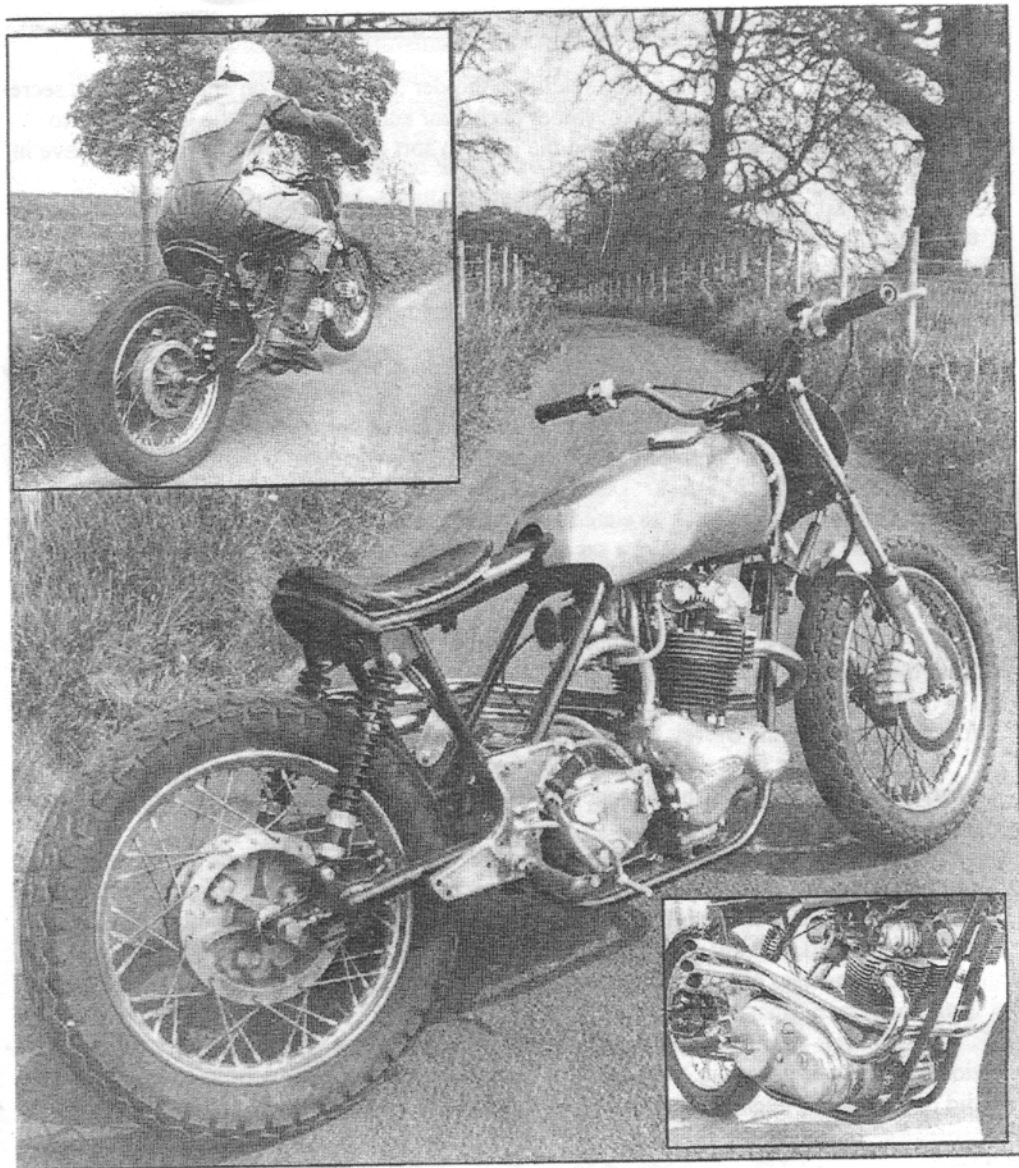

The inspiration for Bryans1 hill climb special that has been ongoing for several years . This may come to light soon as I have cleared space in the garage for to fit my Tr***ph bike in and as I have some space to work around the machine I may get enthused a bit more and get it completed ,who knows what the summer may bring this year.

BRANCH SECRETARIES MEETING .NOVEMBER 2010.

For those of you who do not read Roadholder ,the club has an annual Branch secretaries meeting which is held in November each year and it gets all of the Committee to meet with the Secretaries from around the U.K. to sort out any problems they may have in the running of branches.

The last meeting was held on the last Sunday in November and our intrepid Secretary Garry went along in the snow to represent us from Nottinghamshire, Hurrahh!

My thanks to Garry for sending me the minutes of the meeting (middle of January, thanks to the Tardiness of the main Committee) and I have gleaned a few things to put in our newsletter for you.

The first thing that came across from many secs was the difficulties of attempting to motivate the branches members into taking a greater interest in branch activities.

Peter White ,suggested the NOC prepares a list of speakers who are prepared to attend branches on meeting nights to give a talk, and this idea was welcomed as a potential addition to the "branches pack " being put together by Kev Feltoe.

This leads to the pack as stated above and is meant for new branches that are to be started in the future. It will have a set of the new club rules, a sheet outlining the Secretaries responsibilities, minutes of previous EC,meetings , NOC AGM minutes, new members forms , an e-mail list of the EC ,and a copy of the NOC's Data protection policy.

To this was added ,more bunting, Technical write ups, and more stand materials , from the attendees in the room.

For those branches without a website , Chris Grimmitt has offered to do a design for them based on the Surrey branch one.

Peter White feels that some branches are less successful at encouraging social members to join the club and he renewed his promise to provide new versions of the membership form as soon as possible

The any other business section at the end of the meeting brought Two things to the front and one was that they should bring the meeting to earlier in the year or perhaps have Two meetings , one that might bring the Scots branches down to the meeting and the second was that after asking was the meeting useful? The answer was a resounding ,yes.

The meeting closed at 3:05 pm and meant it had lasted four hours ! That is almost Two hours more than some AGM's ?

P.S. For all those thinking of attending the AGM this year it is being held in the National Railway museum in York and it is not too far away for many of us to have a splendid day out as he museum is free and the city is very close by. See you there?

Bryan the Editor.

Many of us receive Christmas cards from far flung parts of the world and most folks who send them usually take the opportunity to fill them with a letter as it is cheaper in these expensive postal times, and it depends upon when they are written as to what the content is as some folks post early and others post late?

My point is that Steve and Sally ,two of my family friends sent their letter from Brisbane ,Queensland about the start of December and in it all was well The normal pleasantries ,the obligatory what they have been up to during the year and then the wish you would come out here sometime bit!

Now Lynne has received her card from Fred ,a long time Norton Owner from the same area and his letter has all of the disastrous happenings to have hit Queensland and its surroundings ,so this must have been written later than my letter as the two have nothing in common on the subject . They do both say that they look at our weather in Europe and Britain especially and sympathise as we cannot get out and about on the bikes!!

We do know that all parties are safe and well and I hope that any more members of the Norton fraternity who have family and friends out there around the world are all safe and well ,too.

Another thing that they have in common is that this global downturn in financial matters has hit hard there ,too as both Steve and Fred have had to search harder and further from home to keep working and looking after their families , it seems the “no Worries” part of the Aussie culture is really “worried” after all.

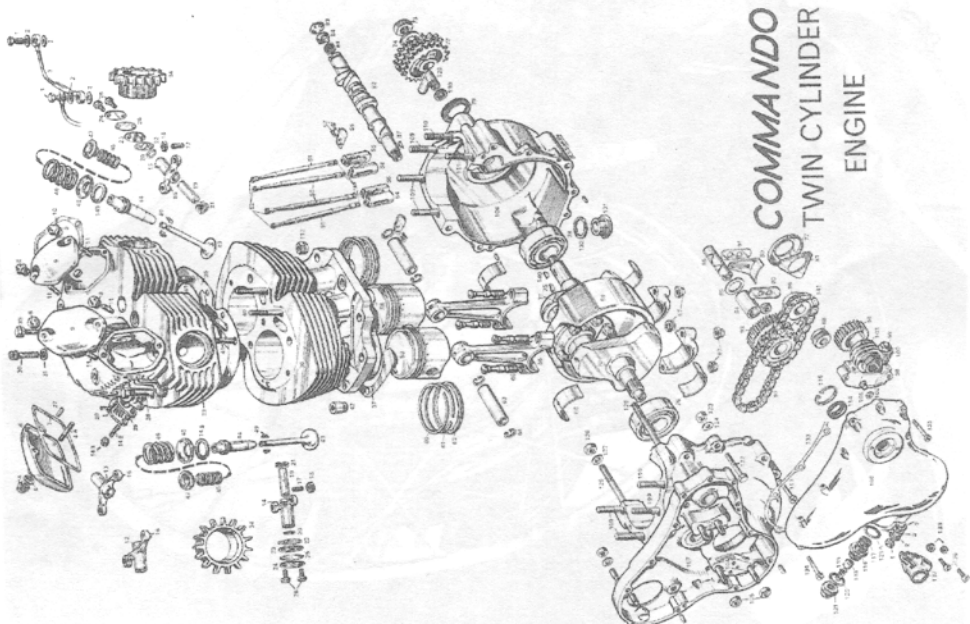



Mercury 650 the big, blue roadscorcher from

Norton

No frills No jazz Just quality For the man who takes his motorcycling *neat* Compact, precise, controllable
The tomorrow motorcycle with a racing heritage
Incomparable Featherbed frame Coil capacitor ignition
Twin contacts New wiring loom G P Mudguards Softer
twinseat And 47 b.h.p. from a no-fuss single concentric
making easier maintenance, more economy
Mercury The big, blue Norton for '69

Norton Villiers Limited, Norton Matchless Division, 44 Plumstead Road, London SE18